

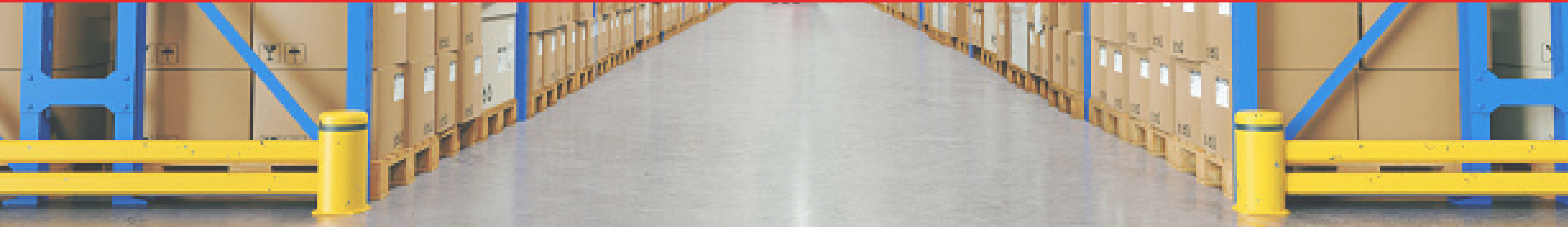

**EFFICIENT TMS**

**Warehouse Protection**



# Overview

Efficient TMS has designed and supplied various types of warehouse protection items, a few listed below.

We do offer a standard range on certain products, however, we find that every customer's need is different, and instead of trying to take our standard products and fit them in their warehouse, we prefer to take inventory of their situation, helping them put the best products in place that may suit their particular needs.

For instance, when looking at bollards we need to ask the customer:

- 1.**Where you intend to place bollards.?
- 2.**What particularly are these bollards there to protect?, e.g walls? Columns? Etc
- 3.**What traffic goes through this area which may cause impact to the bollard? E.g heavy equipment, forklifts, heavy duty vehicles? What are the specific weights and sizes.
- 4.**This all helps us determine the best size and shape of the bollard.

The same theory applies to all our offerings. Barriers, Bumprails, bump stops, nudge bars etc.

Another important consideration is what protection do you use in your other locations?, what problems do you have with those?, if they are working fine then great, lets go ahead and carry on in the same way.

There may be 1 or 2 problems you have encountered with the design, or the stability, maybe your barriers are too bulky and takes up aisle space, maybe your rack protectors aren't designed to take the necessary force. maybe they don't work at all.

These are all thing we can work out on the drawing board to offer you something more appropriate to your situation.

Instead of us telling you what we have  
and why you need it,

We'd prefer you tell us what issues you're  
facing with your current protection items  
needs and we can work with you to help  
overcome them.

Below, are 3 examples of situations where we were able to help our customers overcome their issues through design.

We have also included pictures and drawings of other products we've manufactured, as well as our standard offerings.

## Rack Protection - Tubular Bollard

We have previously supplied a number of different variations of Rack protectors. The most common issues raised are damages from forklifts and other vehicles

Damages from handling equipment can vary based on type of equipment and their dimensions.

For example: in one scenario we were faced with the issue of an overhanging airtank on a forklift which was then damaging the racking because it was at a greater height than their current end aisle protectors.

Our solution then was simple, design a taller protector specific to them that could reduce the impact and position it further away from the rack.

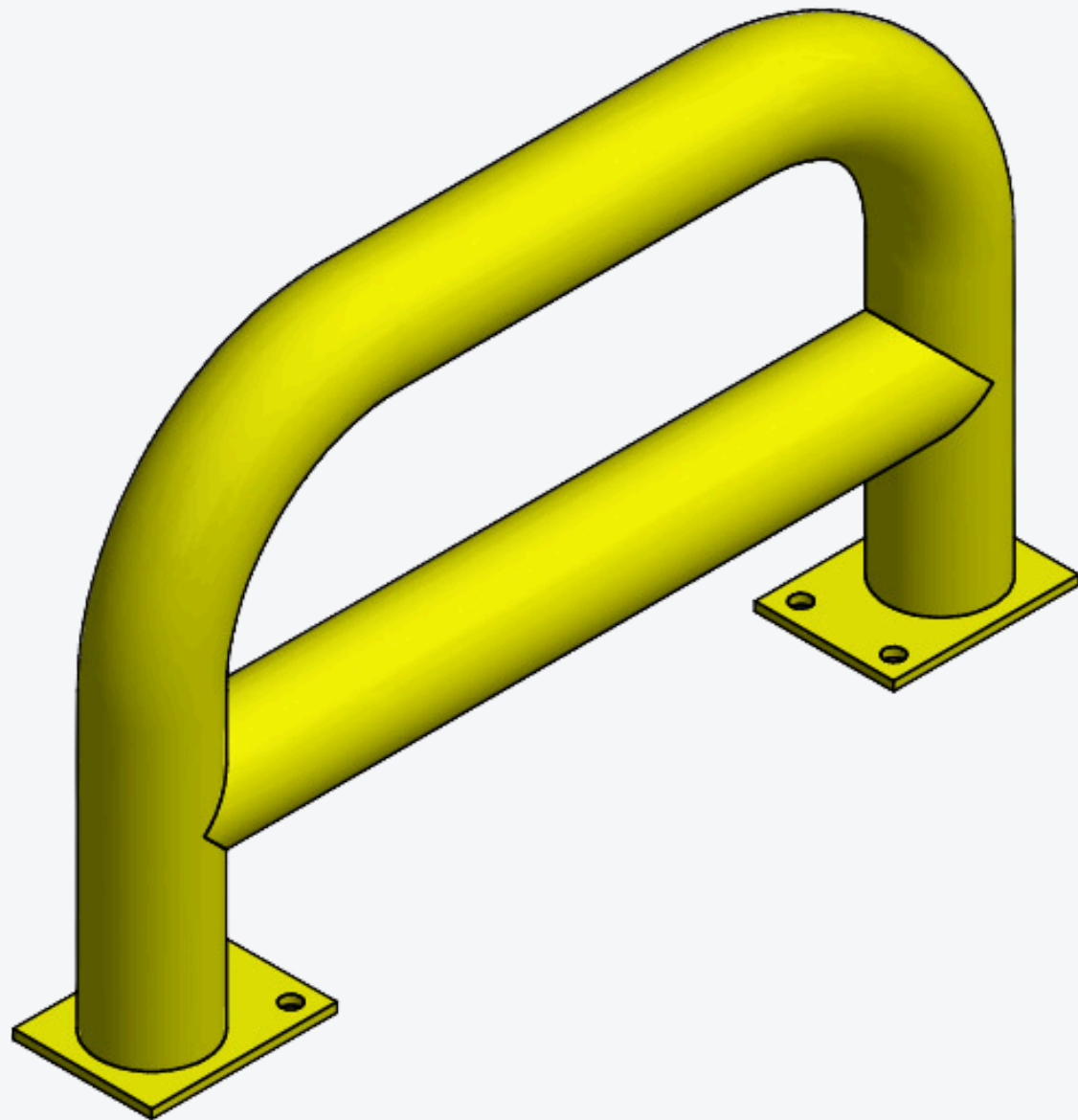

## Conveyor Damage- Bump stops/ Nudge bars

Another customer had a different issue:

Where trolleys continuously caused damage to their conveyor system by bumping into them, their current bumpstops were of no help due to the wheel size or their trolleys,

we therefore, helped develop a larger bumpstop at the correct dimensions to prevent the wheels from going over. The holes in the bumpstop were also made to match the existing holes in their flooring

In this instance a nudgebar was also considered, the bumpstop was more cost effective.

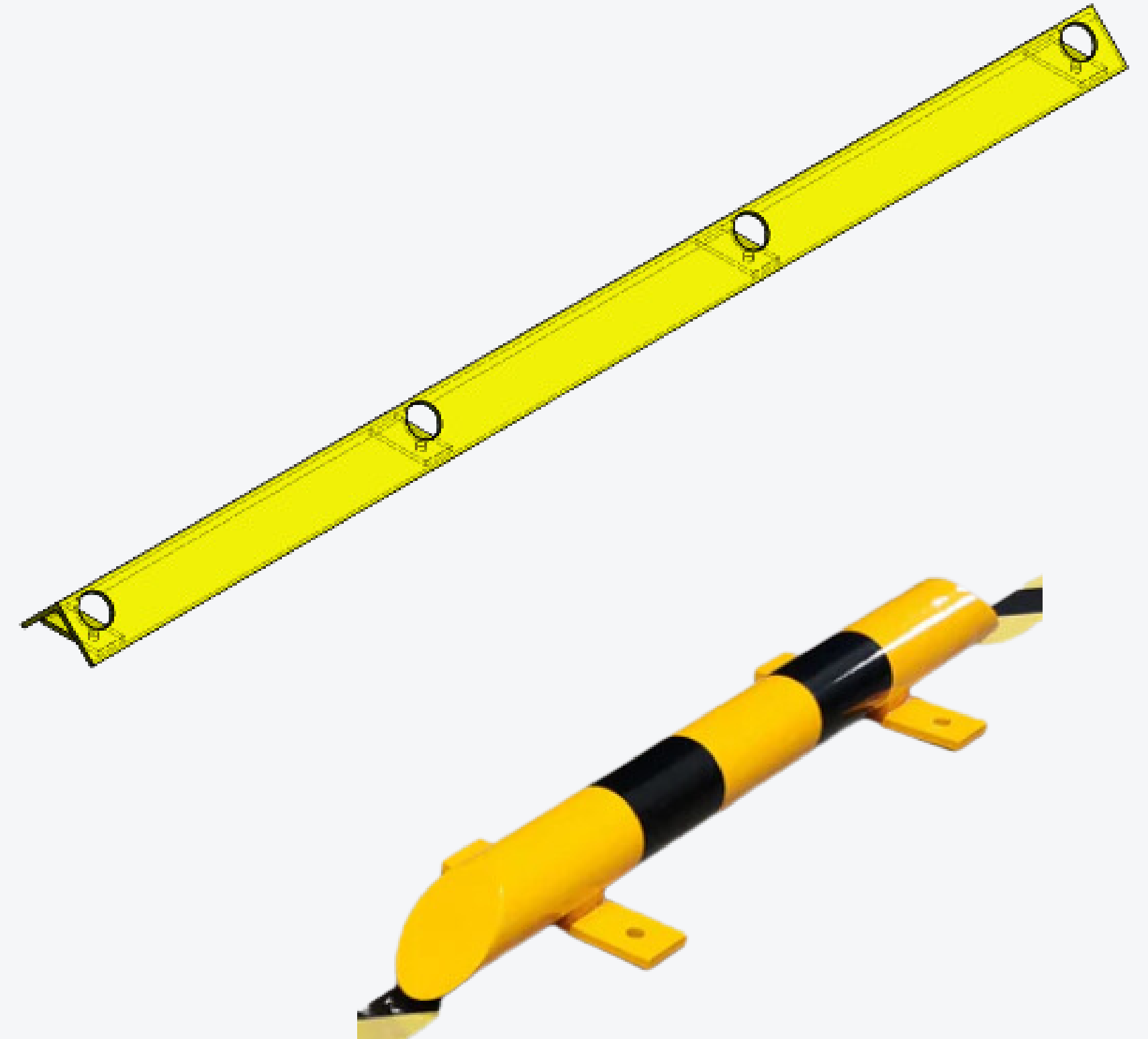



## Out with the new, in with the old- Guardrails and Bumprails

Our customer had originally installed a particular type of guardrail using Armco Barriers, they had then switched to another type which failed to give them the desired level of protection they required. This was due to poor manufacturing quality, breaking at the welds.

They decided to go back to the original design but were unable to find someone who would take the job on until we did.

We had to redraw and design all the parts, we managed to develop a special paint specification to coat the galvanized Armco.

We manufactured and installed 250m of rails.





## Standard Offerings



### Tubular Bollards

Available sizes

76mm Dia x 750mm h

90mm Dia x 900mm h

101mm Dia x 1000mm h

152mm Dia x 1000mm h

152mm Dia x 1500mm h



## Standard Offerings

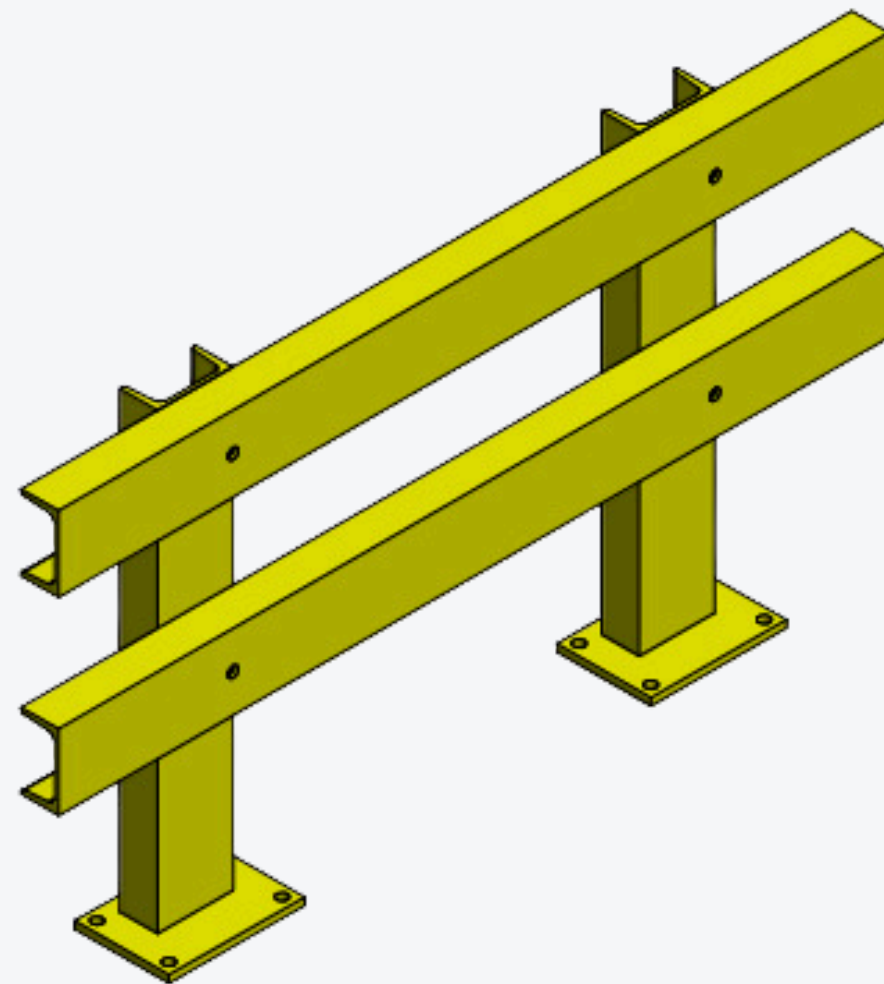

### C-Channel Guardrails

Available sizes

1500mm L 750mm h

3000mm L 750mm h

6000mm L 750mm h

### C-Channel Bumprails

Available sizes

1500mm L 350mm h

3000mm L 350mm h

6000mm L 350mm h



## Standard Offerings



### Rack Protectors Right angle

Available sizes

400mm h x 160mm x 160mm

800mm h x 160mm x 160mm

1200mm h x 160mm x 160mm

### Rack Protectors U-Shape

Available sizes

400mm h x 160mm x 80mm x 80mm

# Standard Offerings

## Pallet Safety Gates



**SEE-SAW LIFT**



**VERTICAL LIFT**

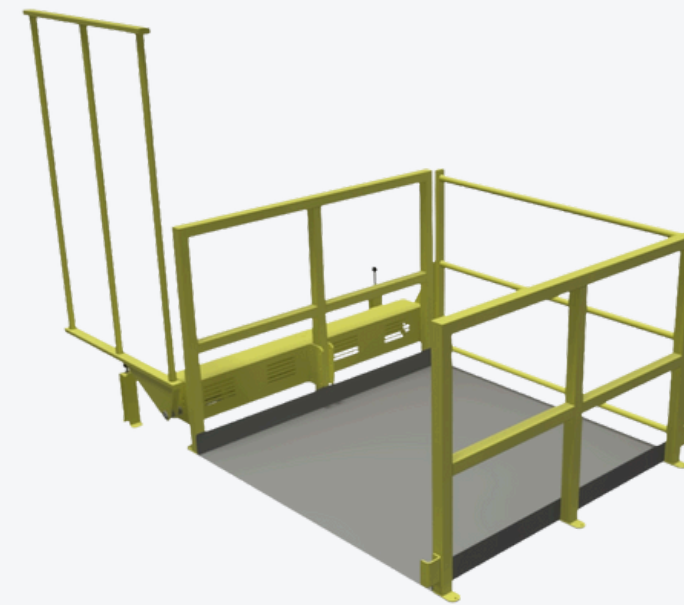

**SPRING LIFT**

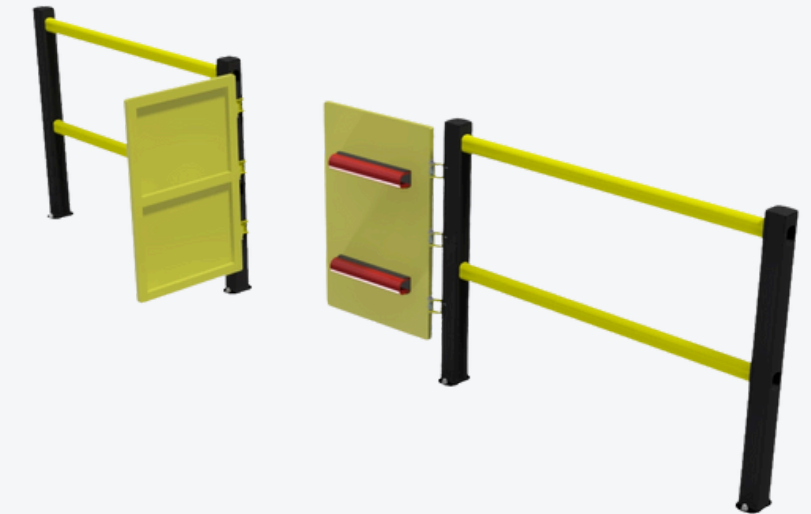

**IMPACT DRIVE GATE**



## Other Warehouse Protection Offerings



**Column  
Protectors**



**Safety  
Fencing**



**Kickplates**



**Tubular Rack  
Protectors**

# We Are Certified



# Some of our Happy Customers!



Global Transport and Logistics



COLGATE-PALMOLIVE

